



# PrimeRite™ CT012P

## 12" x 12" Automatic Dry Priming Pump

### APPLICATIONS:

**Construction Dewatering**

**Sewage Bypass**

**Flood Drainage**

**Mining/Quarries**

**Municipal**

**General Industrial**

The PrimeRite™ is the perfect pump for contractors, pump rental companies, mining operators and general industrial or municipal use. The PrimeRite's™ oil-filled bearing box and a mechanical seal in an oil bath enable it to run dry all day long, making it the right choice for handling inconsistent flows found in sewage bypass pumping and job site dewatering. Units are completely self contained in either skid or trailer configurations with integral lifting bail, tie downs and fuel tank.

### FEATURES

- "Enviro-Safe" priming system, designed for no product leakage
- Vacuum & discharge pressure gauge
- Lockable fuel cap
- Forklift slots (skid models)
- Integral 187 gallon fuel tank with gauge
- Skid or optional trailer mounted
- Torsion bar axle
- DOT light kit available\*
- Hydraulic surge brakes standard, electric brakes available
- Front and rear stabilizing jacks
- 3" Lunette ring for Pintle Hitch - Other options available
- Heavy-duty truck tie downs
- Lifting bail
- Engines - Caterpillar, Perkins, John Deere and Deutz available
- Flexible flywheel coupling
- Volute drain
- 12" ANSI Pattern Flanges – Suction and discharge
- Optional float-activated, Auto Start/Stop controls
- Manufactured in the USA
- Solids handling to 3 1/8"



## CT012 Performance Curve

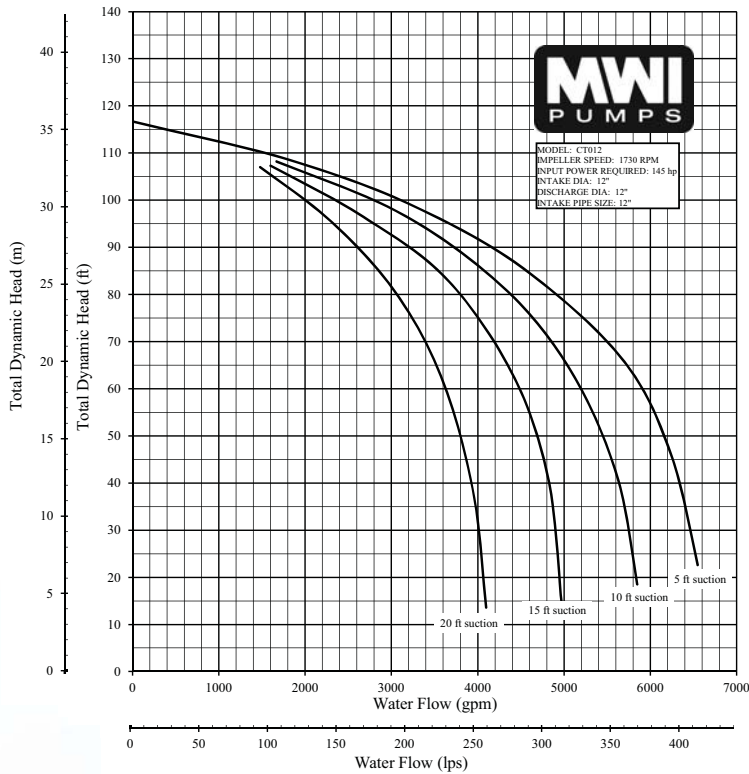

## MATERIALS & SPECIFICATIONS

- Impeller and Wear Plates: Abrasion-resistant materials
- Pump casing: High-grade, spheroidal graphite (ductile) cast iron
- Shaft: Heat treated 1045 steel
- Compressor: Belt-driven, oil lubricated and water cooled
- Priming assembly: Stainless steel venturi
- Control Panel: Tach and hour meter, including shutdowns for: low oil pressure, high coolant temperature and overspeed
- Discharge non-return valve: Val-Matic Swing Flex check valve
- Mechanical seal: Stainless steel with silicon carbide faces
- Weight of trailer mounted unit: 7500 lbs (dry)

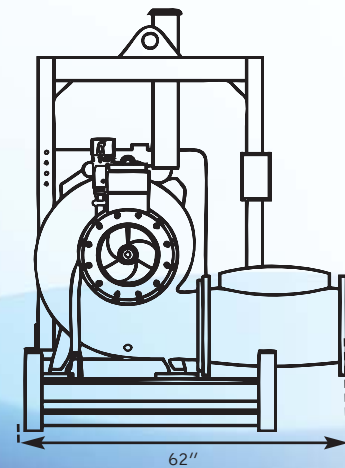
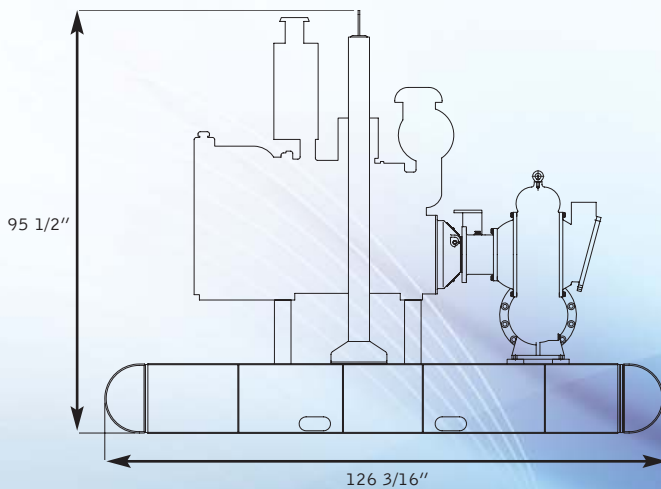

MWI Corp. PrimeRite is a registered trademark. Copyright 2012. All rights reserved. Designs and specifications may change due to continual improvement of our products. P0612

**Moving Water Worldwide Reliably and Efficiently**

201 N. Federal Highway Deerfield Beach, Florida 33441 USA  
 Phone: (954) 426-1500 Fax: (954) 426-1582 E-mail: info@mwicorp.com www.mwipumps.com