

SILENT PARTNER

HEAVY-DUTY SOUND ATTENUATION ENCLOSURE WITH NOISE-ABSORBING INSULATION



APPLICATIONS

Residential Areas

Hospitals

Government
Buildings

Schools

Religious Facilities

*Or wherever else quiet
operations are needed*

The Silent Partner™ is a heavy-duty sound attenuation, quiet pack enclosure that fits the high-performance, automatic-priming, run-dry Primerite™ as well as Hydraflo™, Duraflo™, and Rotoflo™ pumps. This system includes noise-absorbing insulation, which allows the high-performance pumps to run cool and quieter while in sensitive areas such as residential neighborhoods, near hospitals, schools or government buildings. The enclosure also provides easy access to all components no matter what pump is inside.

FEATURES

- Quiet for sensitive areas – with sound levels as low as 67dB at 7M / 23' operating at full rated capacity (based on CPB standards)
- Critically silent pump system – includes engine vibration isolators, priming exhaust muffler and cowl silencer for quiet, trouble free operation
- Runs cool for long engine life
- Fast, easy and safe on-site access to critical components with multiple large access panels, lockable and side-swinging doors to avoid injury and prevent vandalism
- Easy and modular transport – bolt-together design for portability and complete access to components
- Available in skid or DOT highway trailer with lifting bail included
- Radiator access port for external topping off
- External engine oil drain to facilitate oil changes
- Exhaust in secondary enclosure to reduce temperature and keep the inside clean
- Easily remove or add lifting bail, tow bar, axle and bumpers to go from skid to portable or vice versa
- Manufactured in the USA



SILENT PARTNER™ COMPATIBILITY

Primerite™	Automatic Dry Self-Priming Trash Pump
Hydraflo™ (Drive Unit)	Hydraulically-Driven, Large-Volume Submersible Water Pump
Duraflo™ (Drive Unit)	Submersible Hydraulic Trash Pump
Rotoflo™	Wellpoint Dewatering Pump

INSIDE THE BOX

Ideal for use in residential areas or wherever quiet operations are required, the Silent Partner™ is highly favored for a wide range of applications. Because of their heavy-duty design, these pumps can run hard while staying quieter in the most difficult of environments.

Choose from a wide selection of engine control panels for your exclusive quiet pump system. Each panel is designed for fully automated operation and includes fault indicator lights, auto start-stop, and telemetry. The Silent Partner™ can house Primerite™ or Rotoflo™ pumps in its enclosure as well as the drive units for the Hydraflo™ or Duraflo™ pumps.



CONTROL PANEL

MWI offers a wide selection of engine control panels. The engine control panel is protected behind a lockable clear window that provides easy access when needed. The panels are designed for fully automated operation, including fault indicator lights, auto start-stop and telemetry.

DIMENSIONS

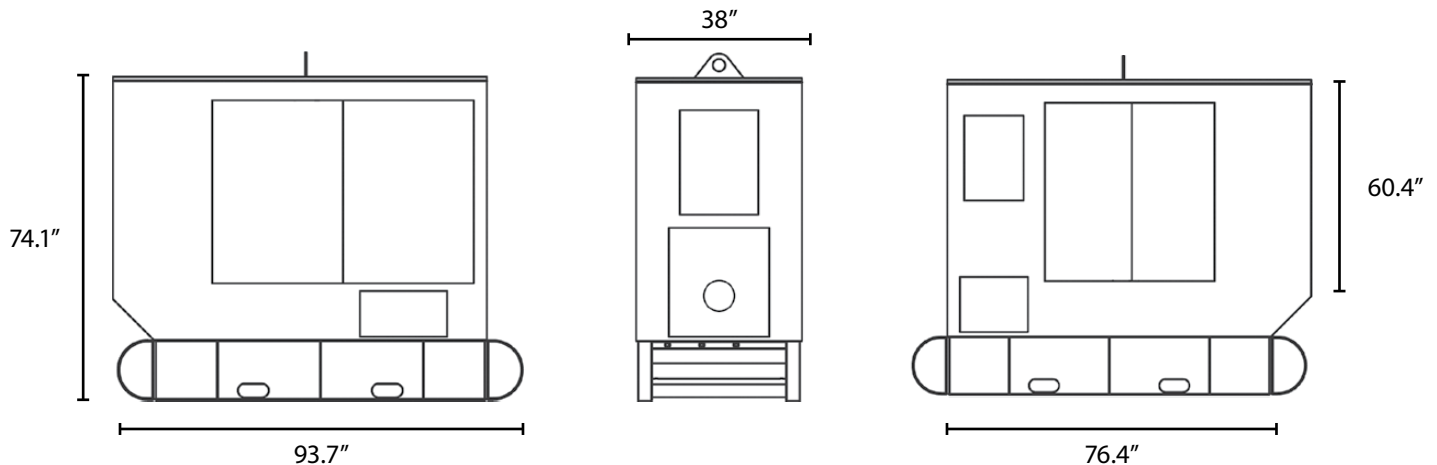

MWI Pumps Headquarters

33 NW 2nd St | Deerfield Beach, FL 33441

Copyright © 2019 MWI Pumps | All rights reserved. Subject to change without notice.

Inquiries: 954-426-1500 | Fax: 954-426-8938 | Email: info@mwipumps.com | mwipumps.com