

# PRIMERITE™ CT012

## 12" X 12" AUTOMATIC DRY SELF-PRIMING TRASH PUMP



### APPLICATIONS

**Construction  
Dewatering**

**Sewage Bypass**

**Flood Drainage**

**Mining/Quarries**

**Municipal**

**General Industrial**

The Primerite™ is the perfect pump for contractors, pump rental companies, mining operators and general industrial or municipal use. The pump's oil-filled bearing box and a mechanical seal in an oil bath enable it to run dry all day long for up to 24 hours, making it the right choice for handling inconsistent flows found in sewage bypass pumping and job site dewatering. This pump is completely self contained in either skid or trailer configurations with integral lifting bail, tie downs and fuel tank.

### FEATURES

- "Enviro-Safe" priming system, designed for no product leakage
- Solids handling to 3.125"
- Vacuum and discharge pressure gauge
- Lockable fuel cap
- Forklift slots (skid models)
- Torsion bar axle
- Integral 198 gallon fuel tank with gauge
- Skid or optional trailer-mounted
- DOT light kit available
- Hydraulic surge brakes standard, electric brakes available
- Front and rear stabilizing jacks
- 3" Lunette ring for pintle hitch – Other options available
- Lifting bail
- Volute drain
- Heavy-duty truck tie downs
- Engines – Caterpillar, Perkins, John Deere and Deutz available
- Flexible flywheel coupling
- 12" ANSI Pattern flanges – Suction and discharge
- Optional float activated, auto start/stop controls
- Manufactured in the USA

### QUICK SPECIFICATIONS

Suction connection	12" 150# ANSI B16.5
Delivery connection	12" 150# ANSI B16.5
Max capacity	6500 GPM
Max solids handling	3.125"
Max impeller diameter	13.8"
Max head (TDH)	117'
Max operating speed	1730 RPM
Max suction lift	24'
Dimensions	63 x 83 x 128"
Sound levels w/ enclosure	67 dBA at 7M / 23'
Max fuel consumption	Up to 24 hrs



## PERFORMANCE CURVE

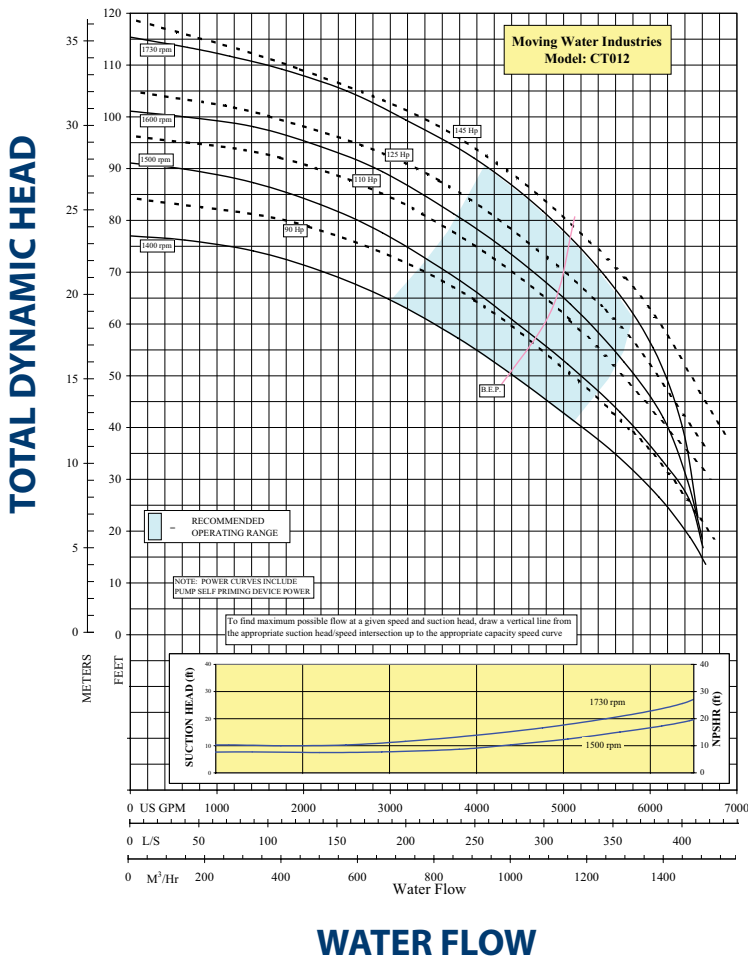

## DIMENSIONS

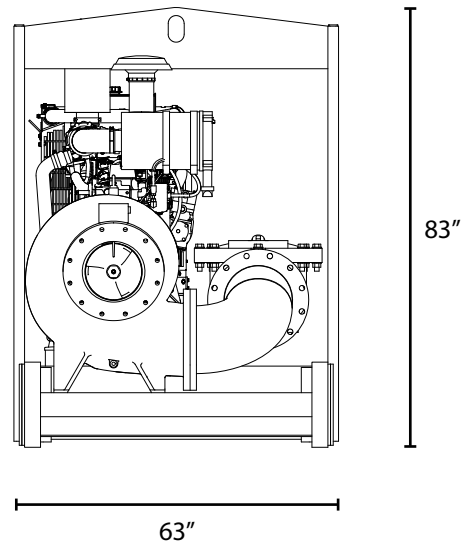
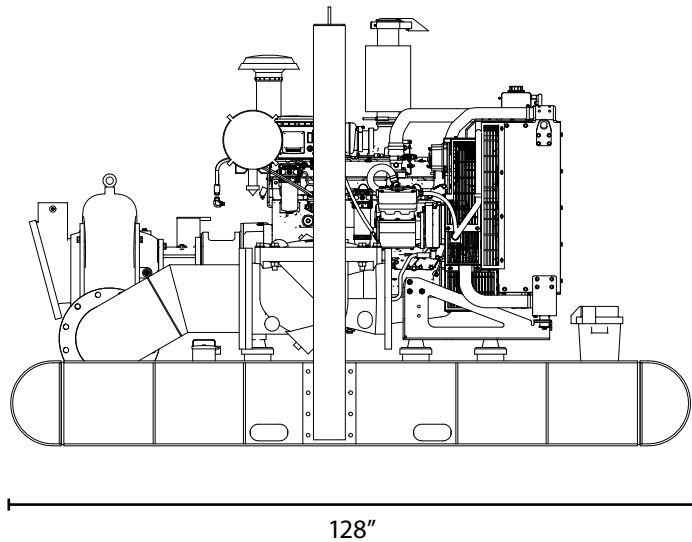

### MWI Pumps Headquarters

33 NW 2nd St | Deerfield Beach, FL 33441

Copyright © 2019 MWI Pumps | All rights reserved. Subject to change without notice.

Inquiries: 954-426-1500 | Fax: 954-426-8938 | Email: info@mwipumps.com | [mwipumps.com](http://mwipumps.com)

## MATERIALS & SPECIFICATIONS

Standard engine	John Deere 6068HF285 (Caterpillar, Perkins, John Deere and Deutz available)
Max HP	156 HP
Fuel capacity	198 Gal
Drive type	Flywheel direct drive flexible element
Impeller	Abrasion resistant materials
Volute	Ductile cast iron ASTM A536 grade 70-50-05
Pump shaft	1045 Steel; Stainless steel option
Compressor	Engine-driven, oil lubricated and water cooled
Priming assembly	304 Stainless steel venturi
Control panel	Tach and hour meter, including shutdowns for low oil pressure, high coolant temperature, Plug-N-Play and float-ready
Discharge non-return valve	Val-matic swing flex check valve ASTM A536 grade 65-45-12
Mechanical seal	Stainless steel with silicon carbide faces; Buna elastomers
Weight of trailer mounted unit	7500 lbs (dry)