

PRIMERITE™ CT006E

6" X 6" ELECTRICALLY-DRIVEN,
AUTOMATIC DRY, SELF-PRIMING TRASH PUMP

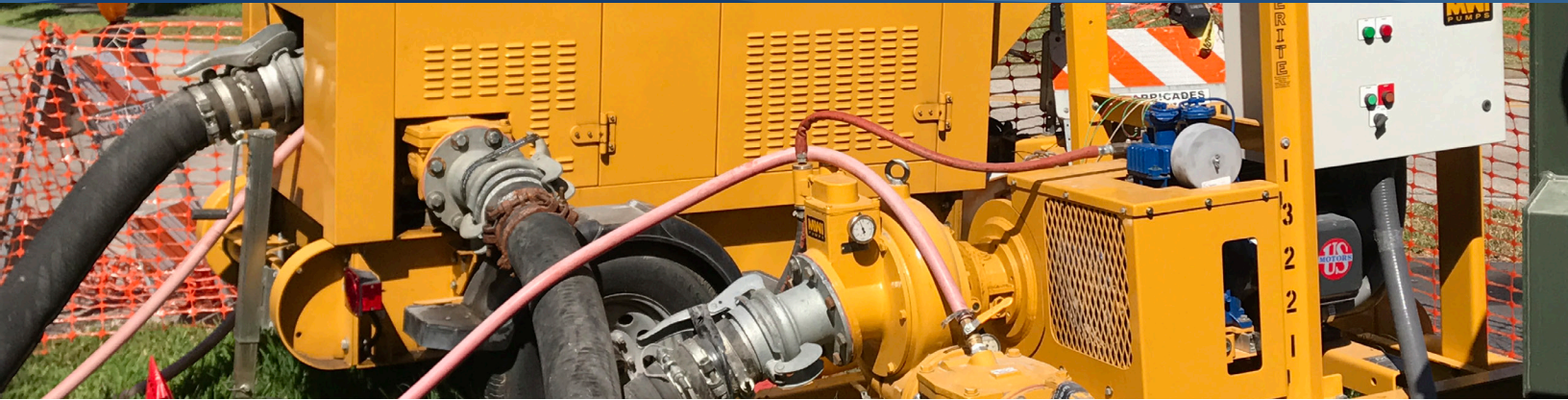

The Primerite™ CT006E is the perfect pump for contractors, pump rental companies, mining operators and general industrial or municipal use. The pump's electrical capabilities make it the right choice for handling inconsistent flows found in sewage bypass pumping and job site dewatering. This pump is completely self contained in either skid or trailer configurations with integral lifting bail and tie down.

FEATURES

- Pump Casing: High-grade, ductile cast iron
- Solids handling up to 3"
- Electrically driven
- Compressor: Belt driven
- Forklift slots (skid models)
- Skid or optional trailer-mounted
- Lifting eye
- Start/stop controls
- Manufactured in the USA

APPLICATIONS

- Construction Dewatering
- Sewage Bypass
- Flood Drainage
- Mining/Quarries
- Municipal
- General Industrial

QUICK SPECIFICATIONS	
Motor Hp (kW)	60 (44.7)
Overload Protection	Yes
Mechanical Seal	Stainless Steel
Max solids handling	3"
Max impeller diameter	10.8"
Voltage	230/460
Max suction lift	25'
Dimensions	37 x 78 x 90"
Mode of Operation	Auto/Manual
Weight on skid mounted unit	3000 lbs



PERFORMANCE CURVE

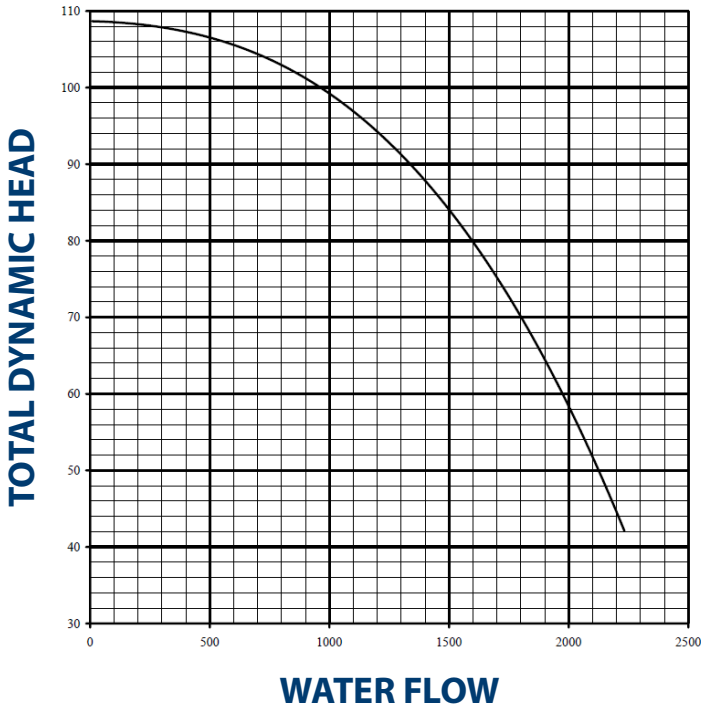

(1) Performance at 1750 RPM

MATERIALS & SPECIFICATIONS

Motor Hp (kW)	60 (44.7)
Phase	3
Voltage	230/460
RPM	1800
Control Panel Type	Combination Soft Starter
Mode of Operation	Auto/Manual
Overload Protection	Yes
E Stop	Yes
Frame	364T
Service Factor	1.15

DIMENSIONS

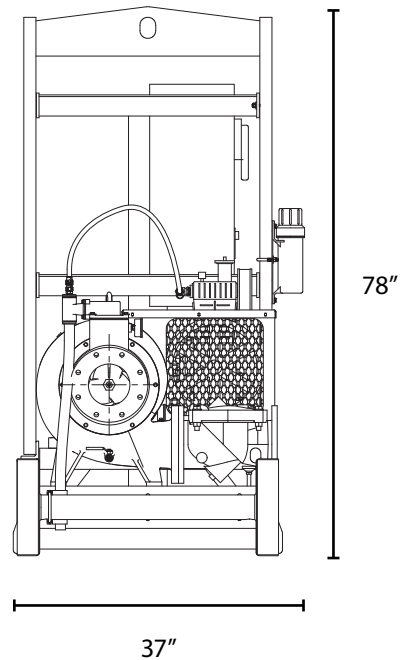
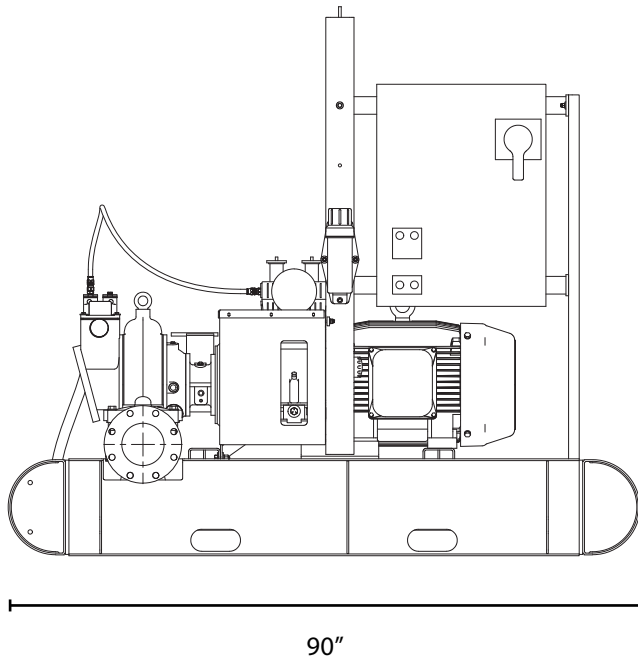

MWI Pumps Headquarters

33 NW 2nd Street | Deerfield Beach, FL 33441

Copyright © 2023 MWI Pumps | All rights reserved. Subject to change without notice.

Inquiries: 954-426-1500 | Fax: 954-426-8938 | Email: info@mwipumps.com | mwipumps.com