

MINEMASTER PRIMERITE™ HHC 10X8

10 X 8" HIGH-HEAD HIGH-LIFT MINING TRASH PUMP



APPLICATIONS

Mining / Quarries

Construction
Dewatering

Sewage Bypass

Flood Drainage

Municipal

Industrial

The Minemaster High-Head Primerite™ HHC 10 x 8 is a powerful trash pump designed to handle the toughest mining jobs in the oil and gas industry and versatile enough to handle numerous industrial applications. These heavy-duty pumps can be used by contractors, pump rental companies, mining operators or for general industrial and municipal use. The units are self-contained and ready to operate in either skid or portable configurations with an open industrial power unit, integral 209 gallon fuel tank, lifting bail, control panel and compressor-driven priming system. The pump is capable of flows to 5,100 GPM and Total Dynamic Heads (TDH) over 280'.

FEATURES

- Primes and reprimed automatically
- Solids handling up to 3.44"
- Engine driven compressor
- Vacuum and discharge pressure gauge
- Lockable fuel cap
- Forklift slots (skid models)
- Torsion bar axle
- Integral 209 gallon fuel tank with gauge
- Skid or optional trailer-mounted
- DOT light kit available
- Hydraulic surge brakes standard, electric brakes available
- Front and rear stabilizing jacks
- 3" Lunette ring for pintle hitch – Other options available
- Lifting bail
- Volute drain
- Heavy-duty truck tie downs
- Engines – Caterpillar, Perkins, John Deere and Deutz available
- Flexible flywheel coupling
- 10" ANSI Pattern flanges – Suction and 8" discharge
- Optional float activated, auto start/stop controls
- Manufactured in the USA

QUICK SPECIFICATIONS

Suction connection	10" 150# ANSI B16.5
Delivery connection	8" 150# ANSI B16.5
Max capacity	5100 GPM
Max solids handling	3.44"
Max impeller diameter	17.3"
Max head (TDH)	280'
Max operating speed	1800 RPM
Max suction lift	24'
Dimensions (skid)	82 x 105 x 175"
Sound levels w/ enclosure	67 dBA at 7M / 23'
Max fuel consumption	At 300 HP; up to 15 hr run time



PERFORMANCE CURVE



TOTAL DYNAMIC HEAD (FT.)

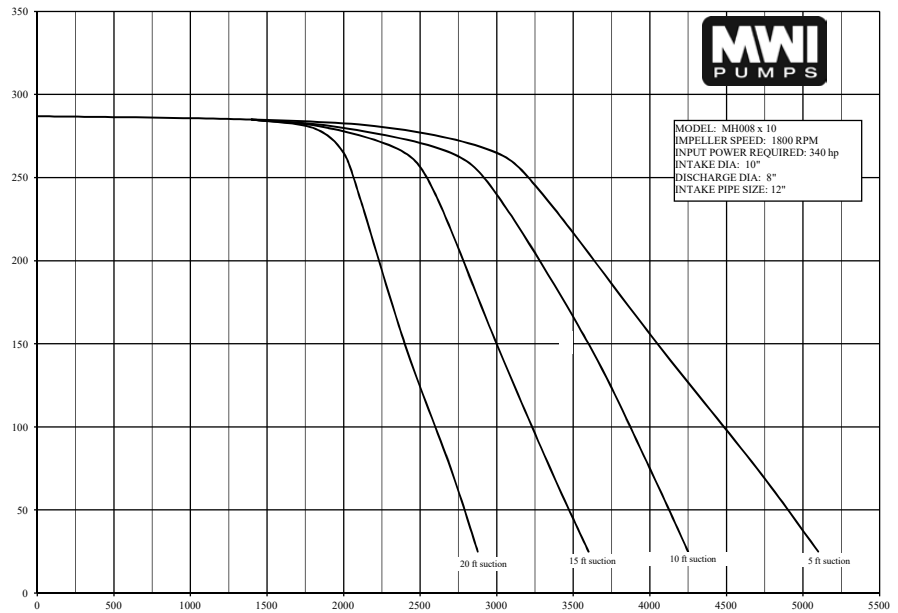

WATER FLOW (GPM)

MATERIALS & SPECIFICATIONS

Standard engine	John Deere 6090HF485 (Caterpillar, Perkins, John Deere and Deutz available)	Priming assembly	304 Stainless steel venturi
Max HP	350 HP	Control panel	Tach and hour meter, including shutdowns for low oil pressure, high coolant temperature, Plug-N-Play and float-ready
Fuel capacity	209 Gal	Discharge non-return valve	Val-matic swing flex check valve ASTM A536 grade 65-45-12
Drive type	Flywheel direct drive flexible element	Mechanical seal	Stainless steel with silicon carbide faces; Buna elastomers
Impeller	CA-40 Corrosion resistant iron/chromium alloy	Weight of trailer mounted unit	6500 lbs (dry)
Volute	Ductile cast iron ASTM A536 grade 70-50-05		
Pump shaft	1045 Steel; Stainless steel option		
Compressor	Engine-driven, oil lubricated and water cooled		

DIMENSIONS

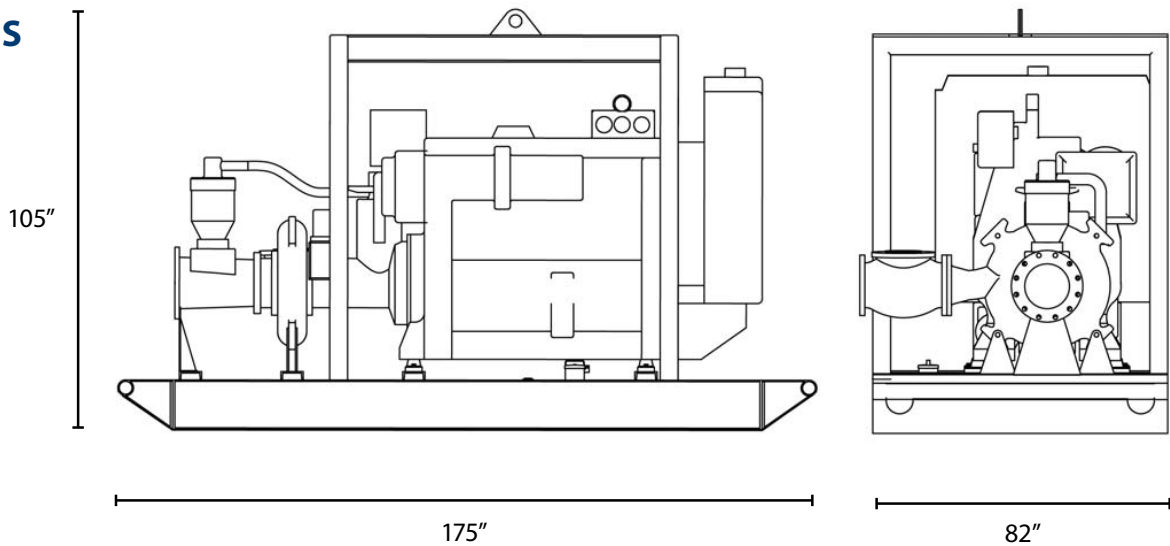

MWI Pumps Headquarters

33 NW 2nd St | Deerfield Beach, FL 33441

Copyright © 2020 MWI Pumps | All rights reserved. Subject to change without notice.

Inquiries: 954-426-1500 | Fax: 954-426-8938 | Email: info@mwipumps.com | mwipumps.com