

ECO PRIMERITE™ CT004

4" X 4" AUTOMATIC DRY SELF-PRIMING TRASH PUMP



APPLICATIONS

Construction
Dewatering

Sewage Bypass

Flood Drainage

Mining/Quarries

Municipal

General Industrial

The Eco Primerite™ self-priming trash pump provides value and efficiency to contractors, pump rental companies, mining operators or municipalities the moment it hits the jobsite. The pump's oil-filled bearing box, mechanical seal in an oil bath and low fuel consumption enables it to run dry all day long for up to 3 days*, making it the right choice for handling inconsistent flows found in sewage bypass pumping and job site dewatering. With flows up to 93' TDH and 1000 GPM, this 4" pump can easily move slurries and brackish water with little maintenance required. This pump is completely self contained in either skid or trailer configurations with integral lifting bail, tie downs and fuel tank.

FEATURES

- Substantial return on investment
- Low fuel consumption - run up to 3 days
- Easily pump slurries/brackish water
- Optimal HP for price/performance
- Lower maintenance costs
- Primes and reprimed automatically
- Solids handling up to 2"
- Engine driven compressor
- Lockable fuel cap
- Vacuum and discharge pressure gauge
- Torsion bar axle
- Integral 28 fuel tank with gauge
- Skid or optional trailer-mounted
- DOT light kit available
- Front and rear stabilizing jacks
- 3" Lunette ring for pintle hitch – Other options available
- Lifting bail
- Volute drain
- Heavy-duty truck tie downs
- Engines – Yanmar 3TNV88
- Flexible flywheel coupling
- 4" ANSI Pattern flanges – Suction and discharge
- Optional float activated, auto start/stop controls
- Manufactured in the USA

QUICK SPECIFICATIONS

Suction connection	4" 150# ANSI B16.5
Delivery connection	4" 150# ANSI B16.5
Max capacity	1000 GPM
Max solids handling	2"
Max impeller diameter	8.7"
Max head (TDH)	93'
Max operating speed	2000 RPM
Max suction lift	28'
Dimensions	60 x 87 x 75"
Sound levels w/ enclosure	67 dBA at 7M / 23'
Max fuel consumption	At 11 HP*; up to 3 days



PERFORMANCE CURVE

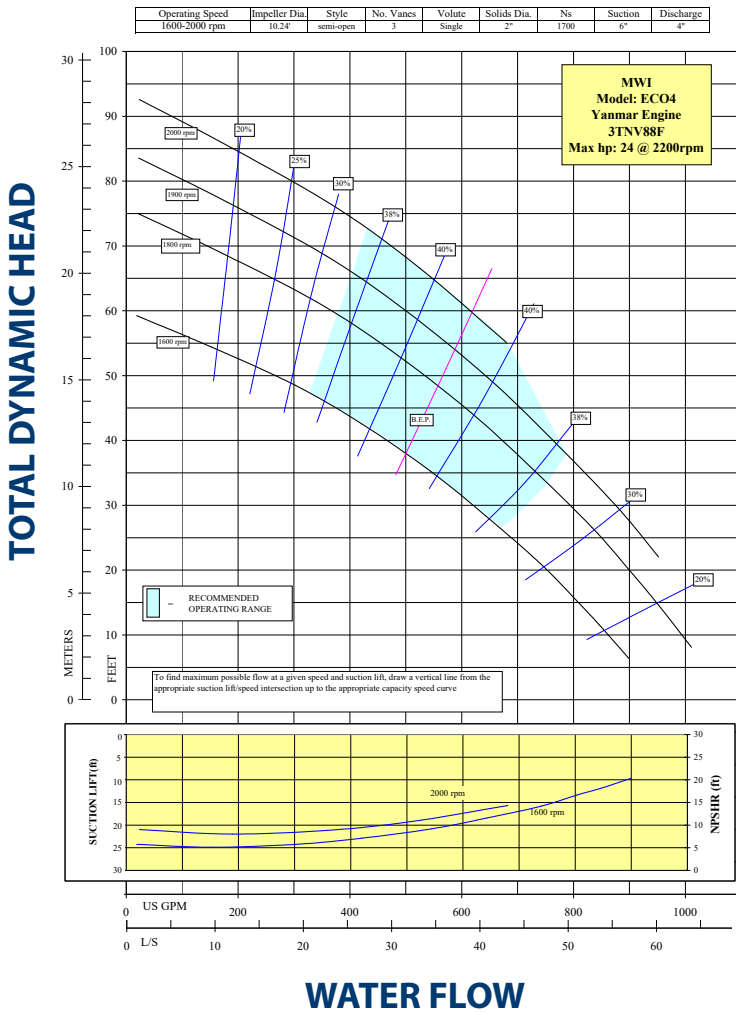

MATERIALS & SPECIFICATIONS

Standard engine	Yanmar engine
Max HP	24 HP
Fuel capacity	28 Gal
Drive type	Flywheel direct drive flexible element
Impeller	High chromium cast iron
Volute	Ductile cast iron ASTM A536 grade 70-50-05
Pump shaft	1045 Steel; Stainless steel option
Compressor	Engine-driven, oil lubricated
Priming assembly	304 Stainless steel venturi
Control panel	Tach and hour meter, including shutdowns for low oil pressure, high coolant temperature, Plug-N-Play and float-ready
Discharge non-return valve	Val-matic swing flex check valve ASTM A536 grade 65-45-12
Mechanical seal	Stainless steel with silicon carbide faces; Buna elastomers
Weight of trailer mounted unit	2300 lbs (dry)

DIMENSIONS

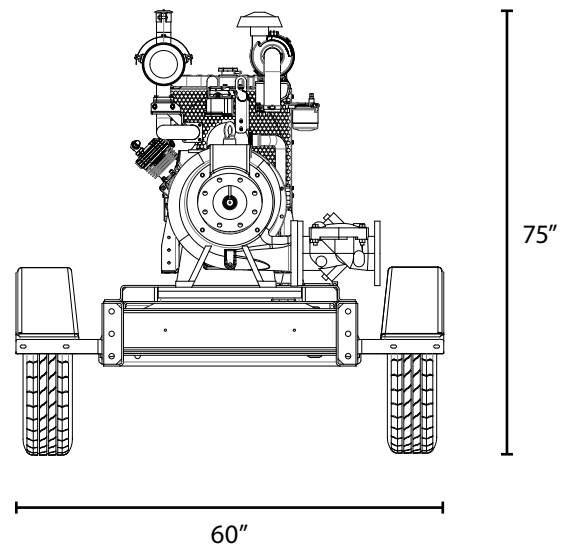
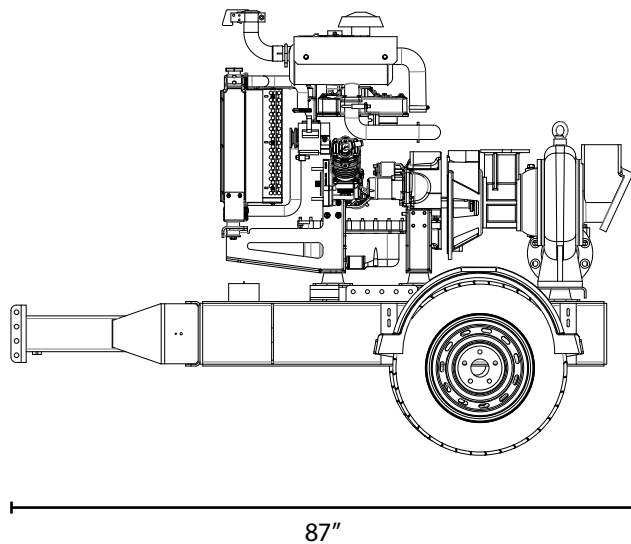

MWI Pumps Headquarters

33 NW 2nd St | Deerfield Beach, FL 33441

Copyright © 2020 MWI Pumps | All rights reserved. Subject to change without notice.

Inquiries: 954-426-1500 | Fax: 954-426-8938 | Email: info@mwipumps.com | mwipumps.com

2-20