

COMPACT ROTOFLO™ RWP006

6" WELLPOINT DEWATERING WATER PUMP



APPLICATIONS

Construction

Wellpoint

Sock Dewatering

Remediation

Recharge

Multiple Fluid
Transfer Capabilities

The Compact Rotoflo™ is a reliable rotary lobe, self-priming, valve-less positive-displacement pump that is made for construction dewatering. Its small, mobile footprint and sound enclosure makes it an agile and unassuming ally when facing tough water pumping challenges in residential neighborhoods or areas where sound must be kept to a minimum. Whether you are using a wellpoint or sock system, the highly-efficient air/water handling capabilities utilizes less fuel while providing less hassles. Additionally, the pump's simple design eliminates the need for complicated vacuum priming, floats and air/water separation systems which are known to be unreliable.

Downtime is substantially reduced thanks to the maintenance-on-site design. Each pump comes with a quick-release cover that can be removed with conventional hand tools to provide easy access to the inner parts without having to remove critical components. Its 100% bolt-together design adds flexibility to your operations by allowing multiple units to be easily combined for maximum output. With inexpensive spare parts, low maintenance, and rugged components, this pump costs less than comparable pump systems and can be set up and running in a fraction of the time.

FEATURES

- High performance (425 GPM and 208' TDH)
- Over 30% smaller and lighter than piston wellpoint pumps - Fits where others can't
- Silent enclosure standard (67dBA at 7M / 23') for residential areas
- Dry running mechanical seals
- Pumps slurries and brackish water
- Choice of diesel engines, electric motors, or hydraulically driven
- Integral 28 gallon fuel tank, gauge and lockable fuel cap
- Positive displacement tri-lobe spiral rotor
- Low fuel consumption - Runs up to 5 days straight
- Pulsation free design
- Skid or trailer available with easy vice-versa conversion
- Rotors, wear plates and seals are easily replaceable on site
- Manufactured in the USA

QUICK SPECIFICATIONS

| | |
|---------------------------|--------------------------------|
| Suction connection | 6" 150# ANSI B16.5 |
| Delivery connection | 6" 150# ANSI B16.5 |
| Max capacity | 425 GPM |
| Max solids handling | 1.6" |
| Max head (TDH) | 208' |
| Max operating speed | 600 RPM |
| Dimensions | 63 x 63 x 83" |
| Sound levels w/ enclosure | 67 dBA at 7M / 23' |
| Max fuel consumption | Up to 5 days depending on load |



PERFORMANCE CURVE

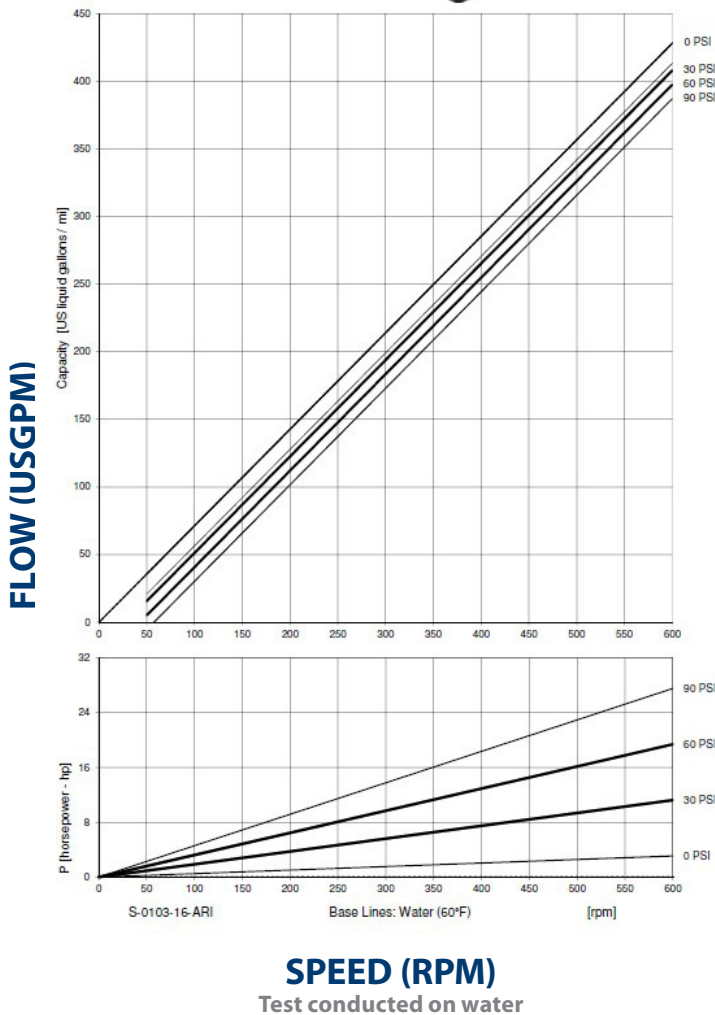

DIMENSIONS

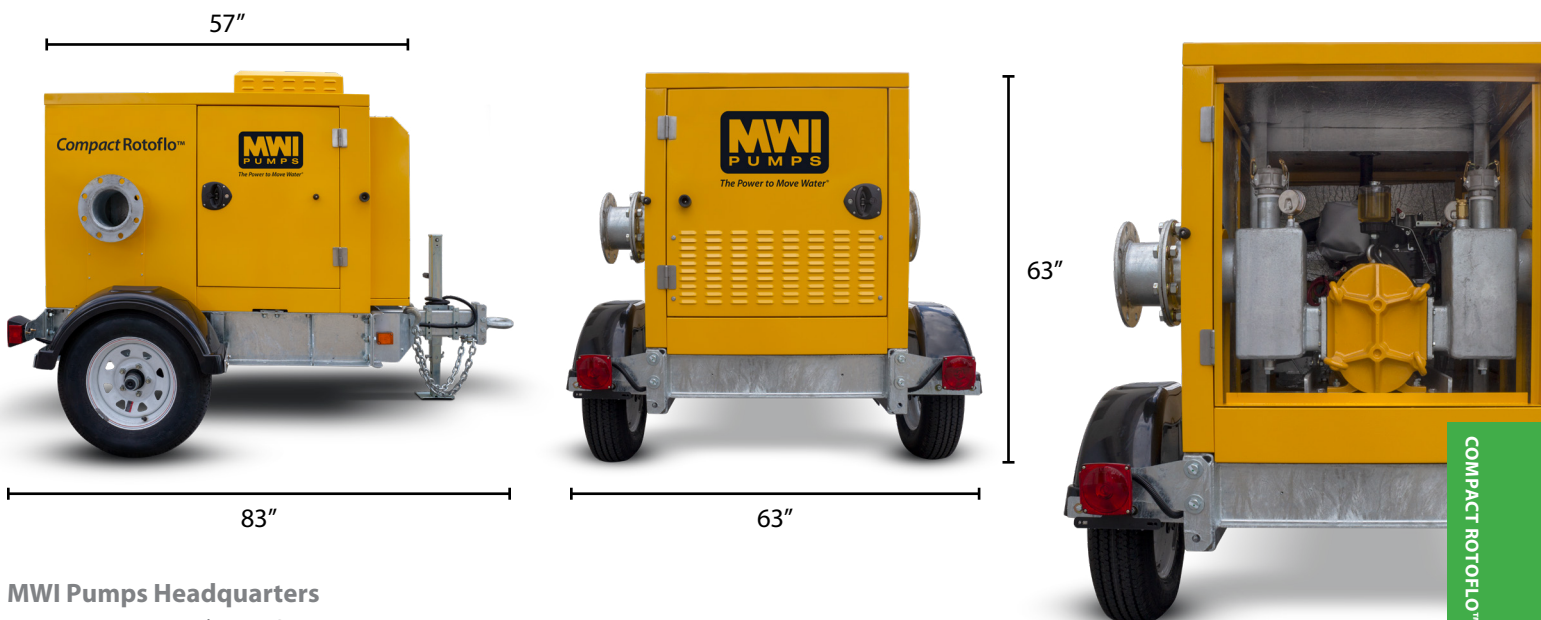

MWI Pumps Headquarters

33 NW 2nd Street | Deerfield Beach, FL 33441

Copyright © 2020 MWI Pumps | All rights reserved. Subject to change without notice.

Inquiries: 954-426-1500 | Fax: 954-426-8938 | Email: info@mwipumps.com | mwipumps.com

MATERIALS & SPECIFICATIONS

| | |
|--------------------------------|--|
| Prime Mover | Choice of diesel, electric, or hydraulically driven motor |
| Pump casing | Single piece construction from cast iron lined with protection plates from stainless steel. Other materials of construction available. |
| Rotors | Low pulsation screw rotor design. Entirely Buna-N elastomer coated. Other elastomer materials available. |
| Wear liner | Stainless steel |
| Shaft material | Non-fluid-wetted from AIS 4140 |
| Discharge | 6" Flapper check valve |
| Mechanical seal | Oil bath, dry running seal, with abrasion resistant silicon carbide faces |
| Sound enclosure | 16-gauge steel lined with sound insulation to achieve 67dBA at 7M / 23' |
| Accessories | Swing-joints, header pipe, wellpoints and jetting equipment |
| Diesel engine panel | Including hour meter and low oil pressure shutdown. |
| Electric panel | Full or reduced starter. Variable frequency drive (VFD) optional. |
| Fuel capacity | 28 Gal |
| Weight of trailer mounted unit | 2425 lbs (dry) |