

CT010 x 6HH

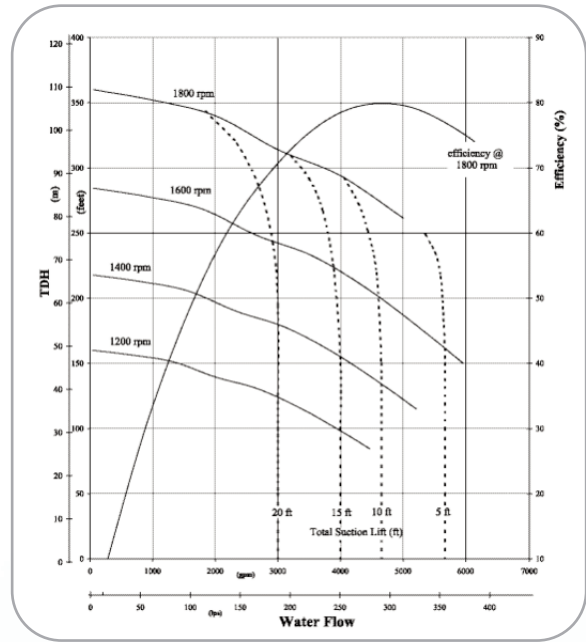

CT010 x 8HH

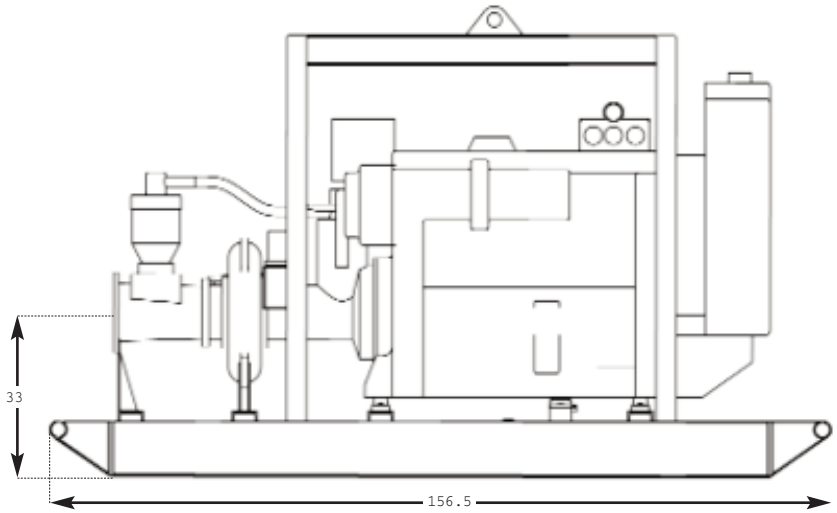
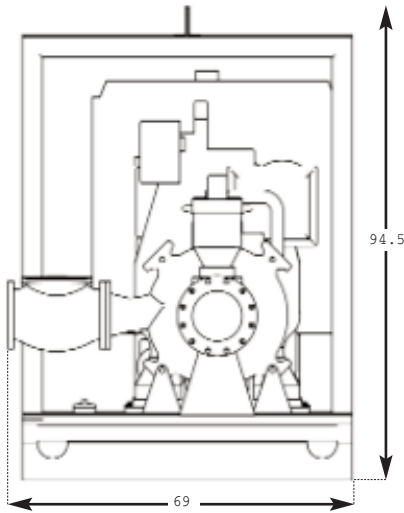

The diagrams above are of MWI s CT010 x 8HH

Model	Size	Motor Model	HP-Motor @ 1800 RPM	Tank	Dimensions L x W x H
CT010 x 6HH	10 x 6	CAT C-7 Other Brands	185HP	662 Liters	2.29 x .81 x 2.03 Meters
CT010 x 8HH	10 x 8	CAT C-15 Available	425 HP	1135 Liters	3.97 x 1.27 x 2.3 Meters



MWI Corp. PrimeRite is a registered trademark. Copyright 2009. All rights reserved. Designs and specifications may change due to continual improvement of our products. P0609

Moving Water Worldwide Reliably and Efficiently

33 NW 2nd St Deerfield Beach, Florida 33441 USA  
 Phone: (954) 426-1500 Fax: (954) 426-1582 E-mail: info@mwipumps.com mwipumps.com